

# KA-60W-T-TH-0001

## Pulse Width Modulator Timer Controlled Motor Drive 60 Watt

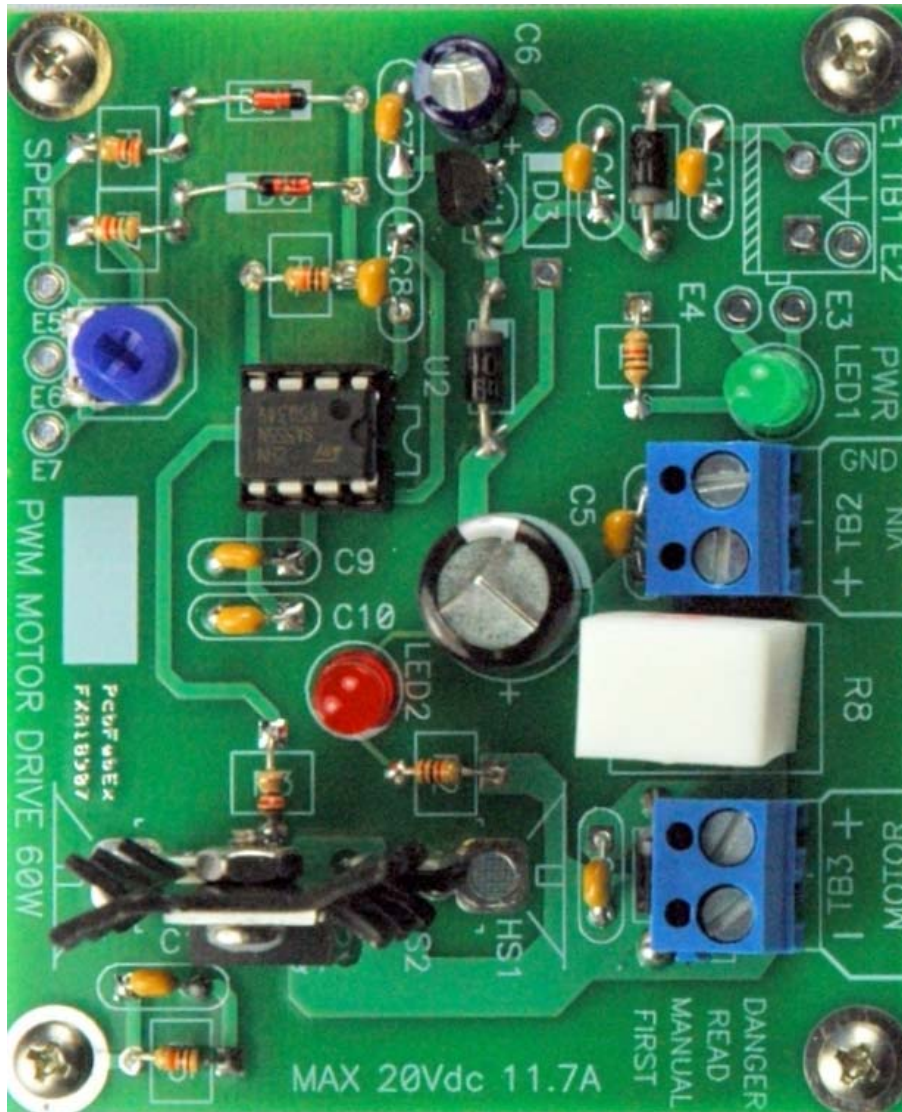

## Assembly Manual

KA-60W-T-TH-0001 Assembly Manual

Revision 1.0

Copyright 2007 CADX Services, Inc. All Rights Reserved.

This document may not be reproduced or transmitted without prior written approval from CADX Services, Inc. CADX Services, Inc. makes NO guarantee regarding the reliability, accuracy, or usefulness of any of the hardware, software, or documentation included with this product.

# Table of Contents

How to Safely Use this Product.....	4
Product Uses.....	5
Product Specifications.....	6
Schematic .....	8
Assembly Drawings.....	9
Parts List.....	9
Assembly Drawing, Page 1 .....	10
Assembly Drawing, Page 2 .....	11
Assembly Instructions for Primary Components .....	12
Bare Board (for reference).....	12
Step 1: 0.1uF TH ceramic capacitors, QTY 6.....	13
Step 2: 0.01uF TH ceramic capacitor (C9).....	14
Step 3: 1.0K TH resistors, QTY 2.....	15
Step 4: 10K TH resistors, QTY 2.....	16
Step 5: 5.1K TH resistor (R7) .....	17
Step 6: 30K TH resistor (R6) .....	18
Step 7: 120 ohm TH resistor (R3).....	19
Step 8: 1N4004 1A, 400V TH GP diodes, QTY 2.....	20
Step 9: 4148 switching diodes, QTY 2 .....	21
Step 10: 1 green LED (LED1).....	22
Step 11: 1 red LED (LED2).....	23
Step 12: 5.0K potentiometer (POT1).....	24
Step 13: 555 timer and socket (U2).....	25
Step 14: 330uF TH electrolytic capacitor (C5) .....	26
Step 15: 0.1 ohm TH resistor (R8).....	27
Step 16: 2-pin terminal blocks, QTY 2.....	28
Step 17: NPN transistor (Q1).....	29
Step 18: Heat Sink (HS1/HS2) .....	30
Optional 5V Regulator.....	31
Step 19: 100uF TH electrolytic capacitor (C6) .....	32
Step 20: 0.1uF TH ceramic capacitors, QTY 2.....	33
Step 21: 5V TH regulator (U1).....	34
Step 22: 1N4004 1A, 400V TH GP diodes, QTY 2.....	35

Configuration for Separate Timer / Driver Power Supplies ..... 36  
Customer Service & Support..... 37  
Disclaimers..... 38  
Software License..... 39

# How to Safely Use this Product

This product should only be assembled, handled or used by adults (over 18), or children **with adult supervision**. Unsupervised children should not be permitted access to this kit or the assembled unit.

This product should only be assembled by someone who has (at minimum) some basic experience using soldering equipment, or who is being instructed by someone with such experience.

**Never allow the assembled unit to run unattended or without adult supervision.**

Make certain that the unit is protected by a 5 amp fuse.

Provide an emergency power shutoff.

This product includes devices sensitive to Electro Static Discharge (ESD) and must be handled accordingly to ensure proper operation.

**Caution: Before operating the unit for the first time, stop to inspect your work for:**

- **Shorts between pins**
- **Unsoldered pins**
- **Devices in the wrong locations**
- **Cracks in the solder joints**

Remember: Safety is always the responsibility of the user.

# Product Uses

Pulse Width Modulators (PWMs) are devices which generate a square wave signal. Over a fixed interval of time they energize the signal for a certain fraction of that interval (this is called the duty cycle).

PWMs can be used to drive LEDs. The longer the duty cycle used, the brighter the LED gets, with shorter duty cycles making the LED dimmer. This is a far better method of driving an LED than simply turning its power on or off, because it gives you direct control over the intensity of the light, and it uses much less power.

PWMs can also be used to drive motors. In this case, longer duty cycles translate to more power to the motor. In addition to being more efficient, it is also much safer, and causes far less wear and tear on the motor; PWM allows you to safely accelerate the motor to the desired speed, and safely decelerate the motor to a stop.

This product is intended primarily as a tool for education, or for a hobby or personal experimentation. It is **not** intended to be used in **any** of the following kinds of applications:

- Commercial
- Industrial
- Medical
- Military

This product **can** be used to **develop** a design which **is** suitable for those applications.

# Product Specifications

**Skill Level (1-5): 3**

## **Kit Includes:**

- Printed circuit board (Premium quality FR4)
- LM555 - CMOS Timer
- Manual, Schematics, Bill of Materials
- Package of appropriate components for assembly

## **Features:**

- 555 Timer Astable Multivibrator (Variable Duty Cycle oscillator)
- Easy frequency and duty cycle changes
- Power indicator (Green LED)
- Diagnostic LEDs for development (RED LEDs)
- Remote Control Panel (External wire connection for POT1 )
- Complete Schematics (PDF Format)
- Complete Bill of Materials (PDF Format)
- Safety and protection components included or referenced
- Power MOSFET TO-220 3 Amps
- PWM Duty Cycle capable: 10-90%
- PWM Base Frequency Factory: 10KHz
- Hardware based PWM Timer

## **Absolute Maximum Ratings**

- Input Voltage: 20 VDC (7.5-20VDC, **12VDC Nominal**)
- Output Voltage: 20 VDC (7.5-20VDC, **12VDC Nominal**)
- Current Sink: 3 Amps
- Power Control: 60 Watts

## **Absolute Maximum Environment Ratings**

- Environment Temperature Optimal: 25 C
- Environment Temperature range: -30 to 70 C

## Physical Traits

- PCB Size: 3.0" x 2.5", 0.062" thick
- Layers: Double Sided
- Weight: 2 oz (approximate)
- Total lifetime: N/A

## Recommended Accessories:

- **Mounting hardware:** 4-40 Screws, nuts and washers

# Schematic

The schematic for this design can be found in a separate Adobe Acrobat PDF.

The link to this document is back on the startup page that popped up when you first explored the CD for this product.



# Assembly Drawings

## Parts List

QTY	Ref. Designator	Description
1	PCB1	PCB, KF-PWM-60W-T-TH-X, 3X2.5, 2 LY, GRN, TH
<b>2</b>	<b>C1, C4</b>	<b>CAP, CER DISC, 0.1uF, 10%, 50V, TH, RADIAL</b>
<b>1</b>	<b>C6</b>	<b>CAP, ALUM, 100uF, 20%, 25V, TH, RADIAL</b>
<b>2</b>	<b>D2, D4</b>	<b>DIODE, GP, 1A, 400V, TH, DO-41</b>
<b>1</b>	<b>U1</b>	<b>IC, 3-Terminal Positive Voltage Regulator 5V</b>
<b>1</b>	<b>TB1</b>	<b>TERM, 2-PIN, VERT SCREW CLAMP, 22-14 AWG, 5.08MM</b>
1	C5	CAP, ALUM, 330uF, 20%, 50V, TH, RADIAL
1	C9	CAP, CER DISC, 0.01uF, 10%, 50V, TH, RADIAL
6	C2, C3, C7, C8, C10, C11	CAP, CER DISC, 0.1uF, 10%, 50V, TH, RADIAL
1	D1, D3	DIODE, GP, 1A, 400V, TH, DO-41
1	LED1	DIODE, LED GREEN, 75mW, 2.1V, 10mA, TH
1	LED2	DIODE, LED RED, 60mW, 2.0V, 10mA, TH
2	D5, D6	DIODE, SWITCHING, 75V, TH, DO-35
1	HS1 / HS2	HEAT SINK
1	U2	IC, TIMER, 555, 5V, DIP8-300, TH
1	XU2	SOCKET, DIP-8, TH
1	POT1	POT, LINEAR, 300D, 5.0K, 5%, 150V, 0.8W, PANEL, TH
2	R1, R2	RES, CF, 1.0K, 5%, 150V, 1/6W, TH, RES265
1	R7	RES, CF, 5.1K, 5%, 150V, 1/6W, TH, RES265
2	R4, R5	RES, CF, 10K, 5%, 150V, 1/6W, TH, RES265
1	R6	RES, CF, 30K, 5%, 150V, 1/6W, TH, RES265
1	R3	RES, CF, 120, 5%, 150V, 1/6W, TH, RES265
1	R8	RES, WIRE, 0.1, 5%, 350V, 5W, TH, RADIAL
2	TB2, TB3	TERM, 2-PIN, VERT SCREW CLAMP, 22-14 AWG, 5.08MM
1	Q1	TRANS, TP31, NPN, Vce100v, Ic=3000mA, TH, TO-220

Parts in bold are for the optional 5V regulator

# Assembly Drawing, Page 1

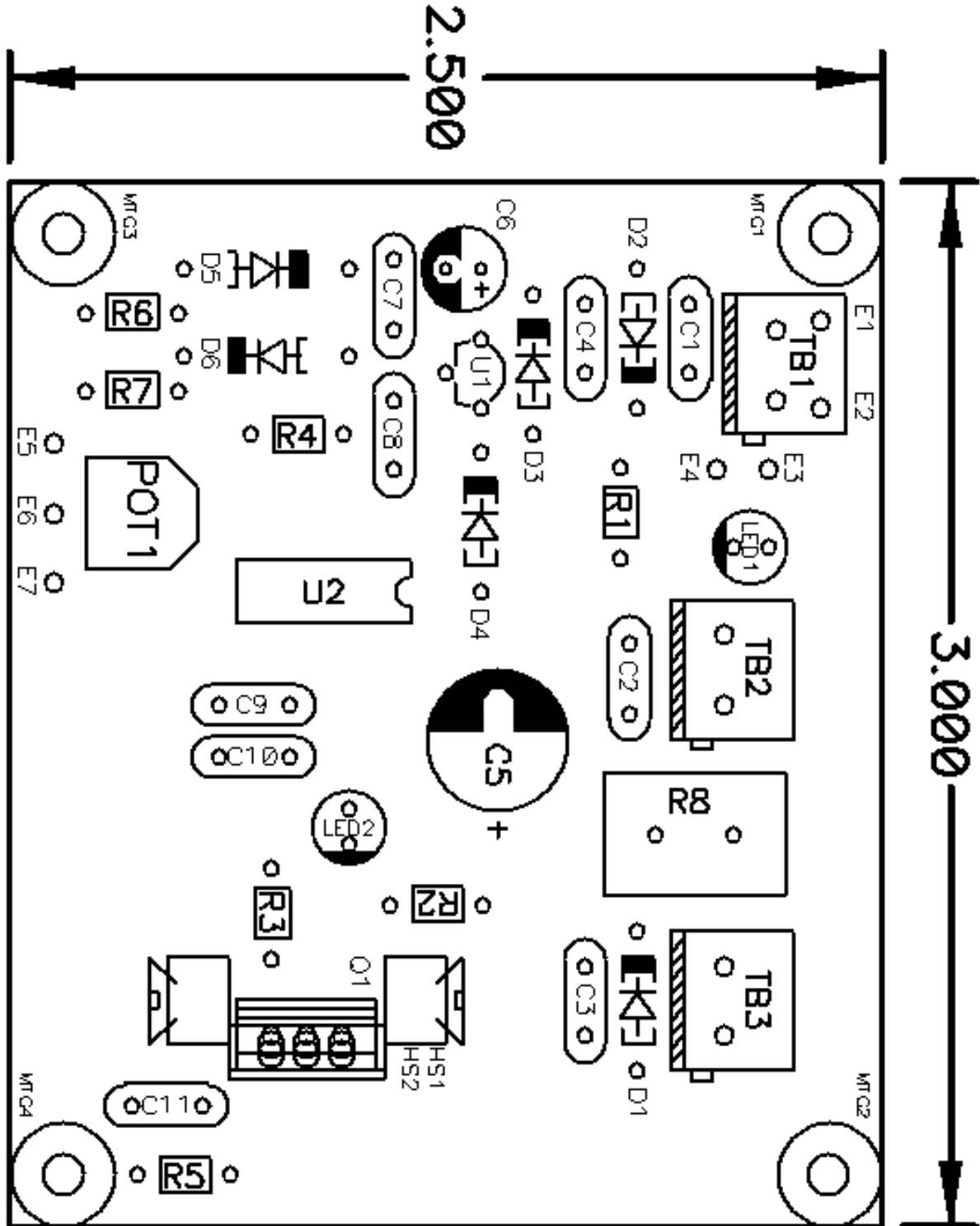

Figure 1: Component Locations and Reference Designators. Board rotated 90 degrees.

# Assembly Drawing, Page 2

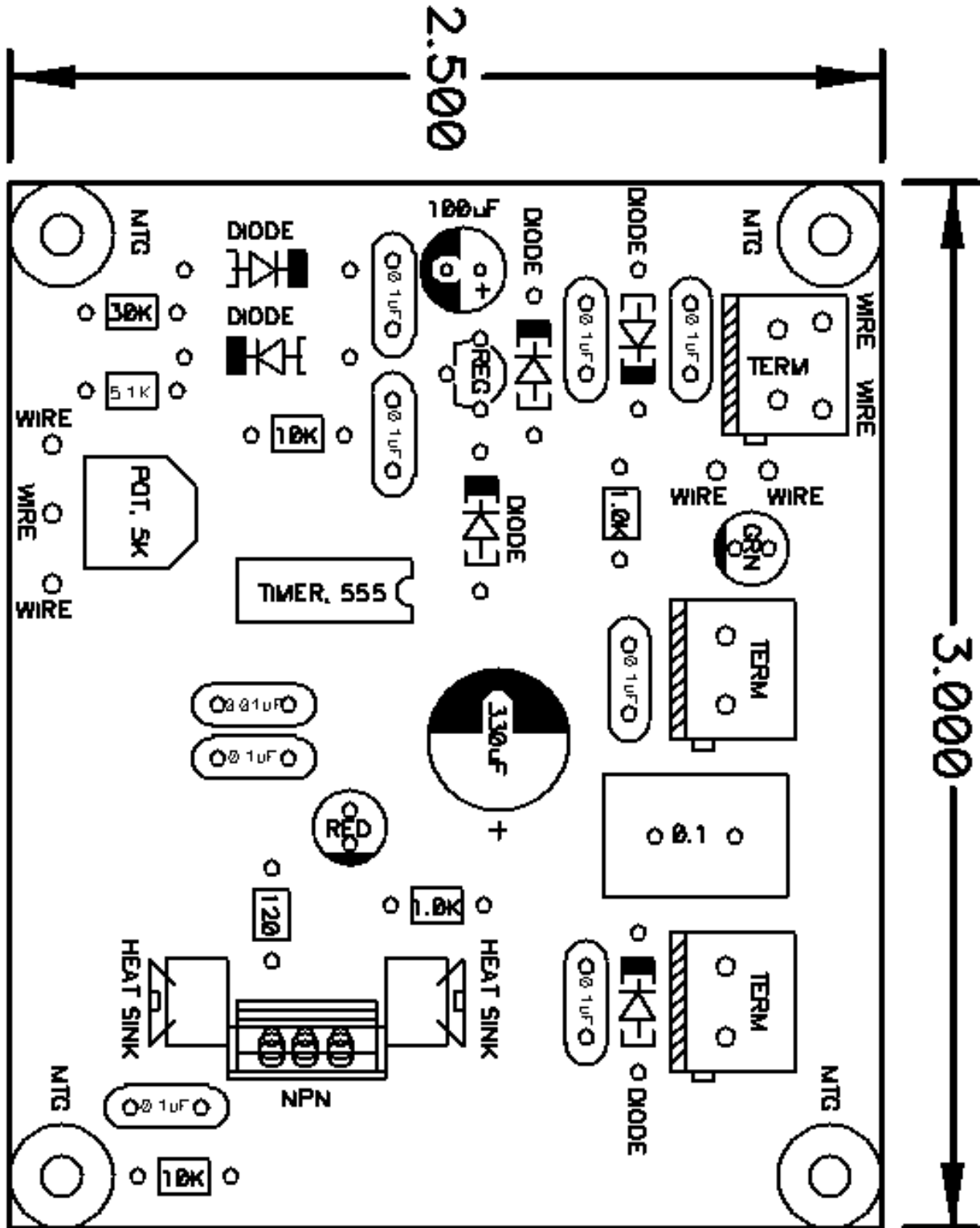

Figure 2: Component Values. Board rotated 90 degrees.

# Assembly Instructions for Primary Components

## *Bare Board (for reference)*

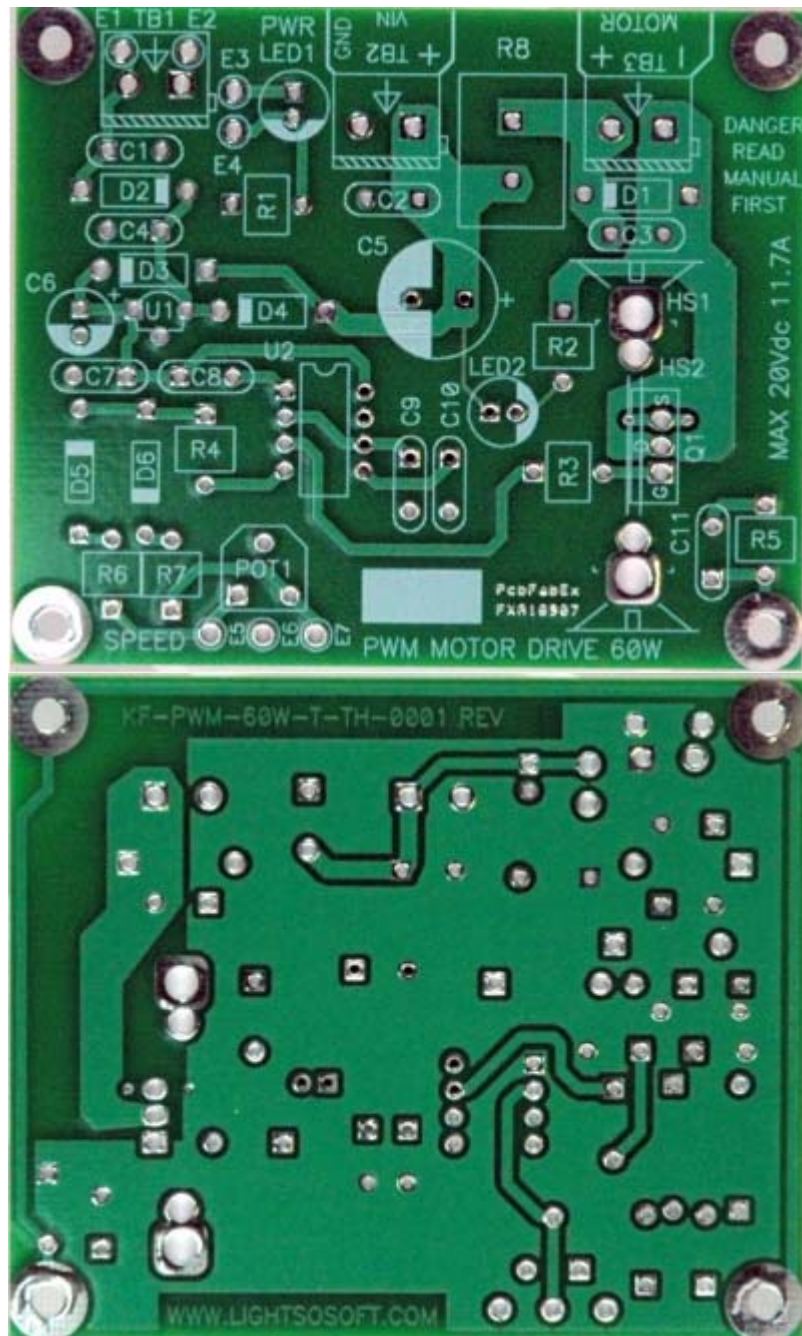

Figure 3: Board with no components installed, top and bottom sides.

## Step 1: 0.1uF TH ceramic capacitors, QTY 6 C2, C3, C7, C8, C10, C11

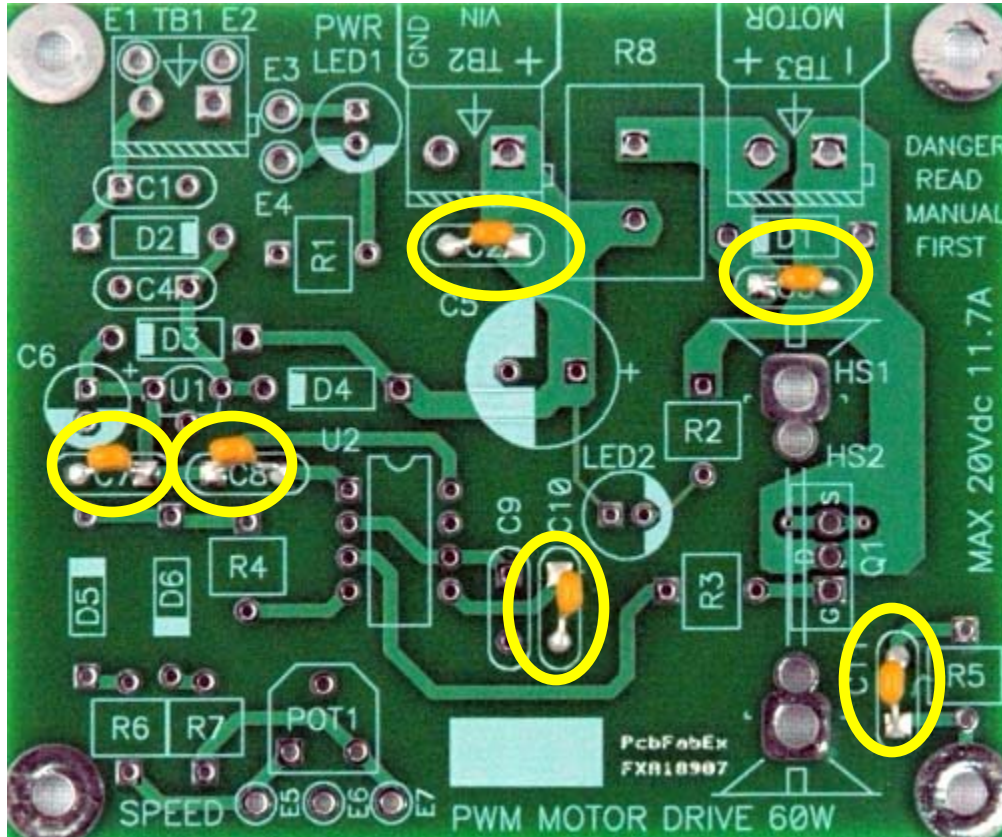

Figure 4: Board with 0.1uF ceramic capacitors installed.

From the kit, locate 5 pieces of the 0.1uF ceramic capacitor.

Find the locations for these parts on the board, marked C2, C3, C7, C10, C11.

At each location, insert the capacitor's leads through the plated holes.

On the back side of the board, bend the leads at 90-degree angles so that the parts are held in place when you solder them. Once you've soldered the leads in place, trim and discard the excess lead length.

## Step 2: 0.01uF TH ceramic capacitor (C9)

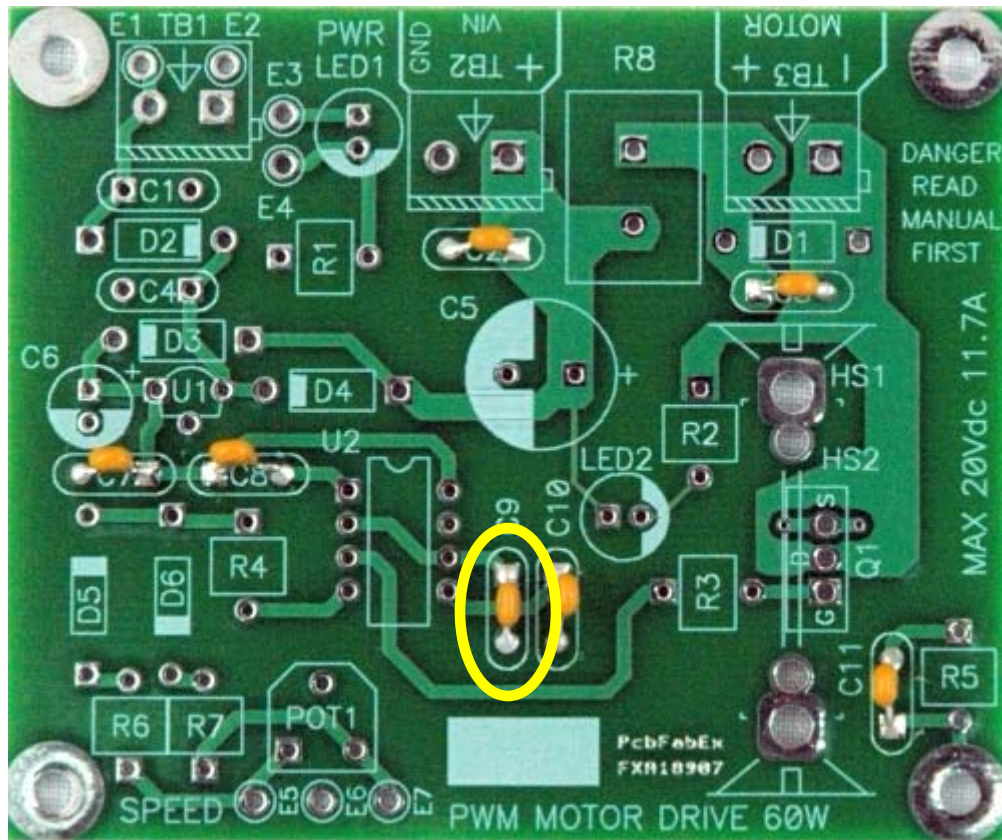

Figure 5: Board with 0.01uF capacitor installed.

From the kit, locate 1 piece of the 0.01uF ceramic capacitor.

Find the locations for this part on the board, marked C9.

At this location, insert the capacitor's leads through the plated holes.

On the back side of the board, bend the leads at 90-degree angles so that the parts are held in place when you solder them. Once you've soldered the leads in place, trim and discard the excess lead length.

### Step 3: 1.0K TH resistors, QTY 2 R1, R2

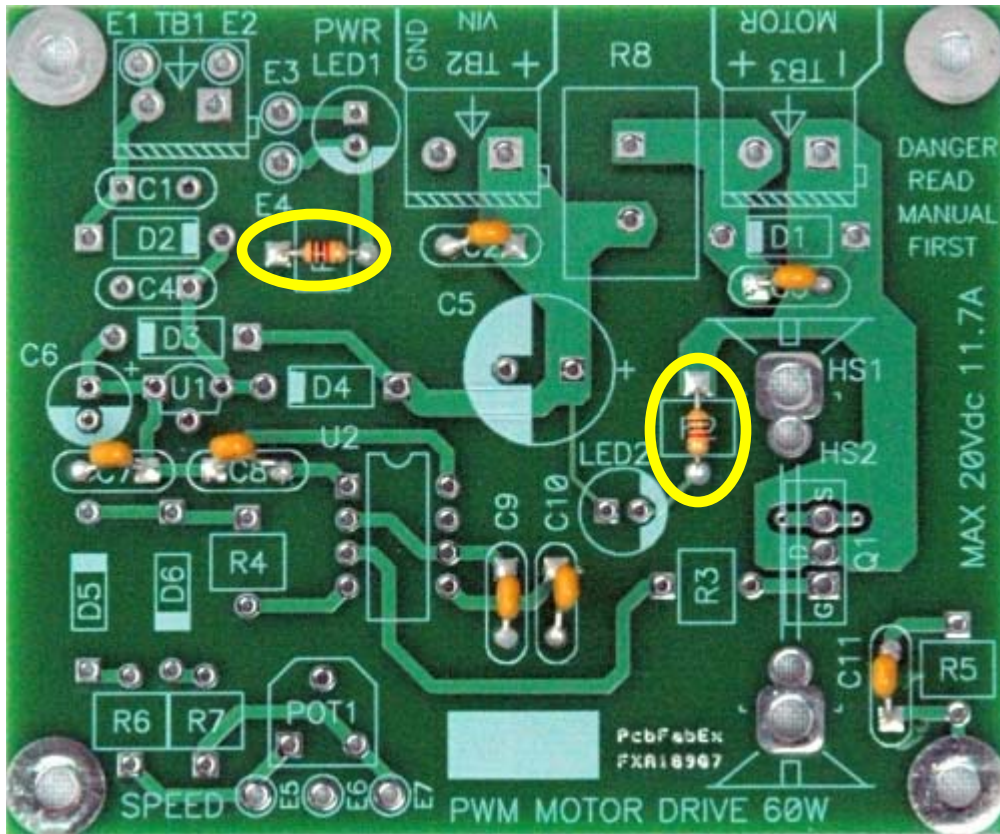

Figure 6: Board with 1.0K resistors installed.

From the kit, locate 2 pieces of the 1.0K resistor.

Find the locations for these parts on the board, marked R1 & R2.

At each location, insert the resistor's leads through the plated holes.

On the back side of the board, bend the leads at 90-degree angles so that the parts are held in place when you solder them. Once you've soldered the leads in place, trim and discard the excess lead length.

## Step 4: 10K TH resistors, QTY 2 R4, R5

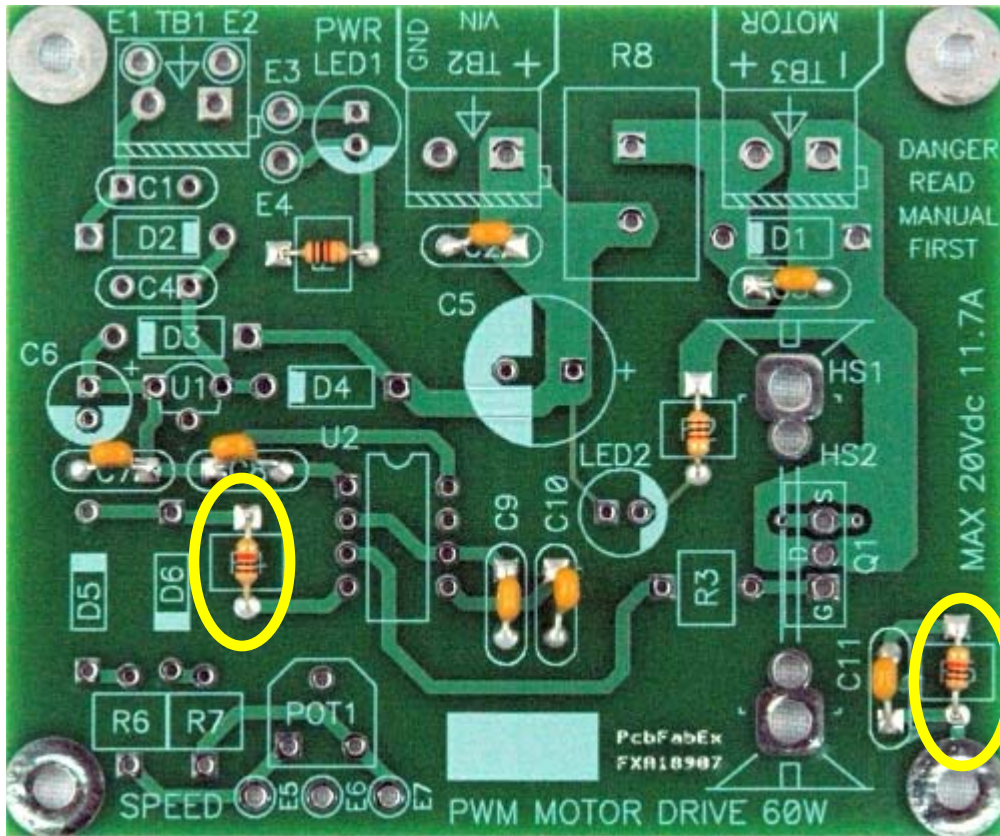

Figure 7: Board with 10K resistors installed.

From the kit, locate 2 pieces of the 10K resistor.

Find the locations for these parts on the board, marked R4 & R5.

At each location, insert the resistor's leads through the plated holes.

On the back side of the board, bend the leads at 90-degree angles so that the parts are held in place when you solder them. Once you've soldered the leads in place, trim and discard the excess lead length.



## Step 5: 5.1K TH resistor (R7)

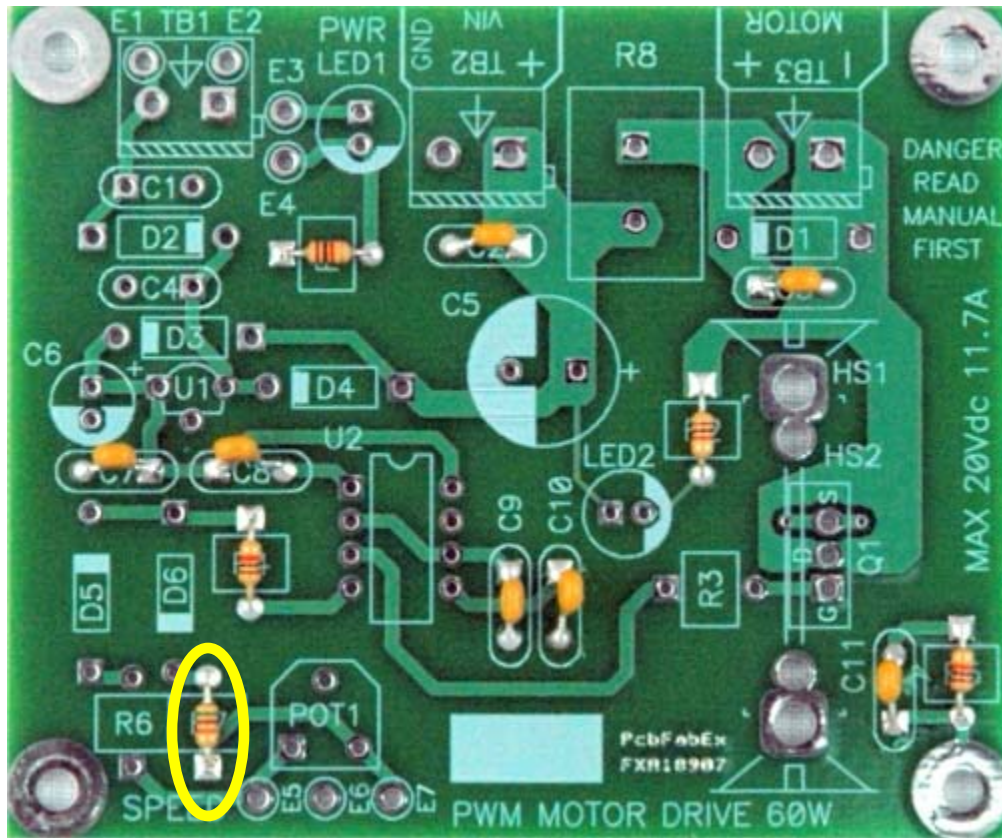

Figure 8: Board with 5.1K resistor installed.

From the kit, locate 1 piece of the 5.1K resistor.

Find the location for this part on the board, marked R7.

At this location, insert the resistor's leads through the plated holes.

On the back side of the board, bend the leads at 90-degree angles so that the parts are held in place when you solder them. Once you've soldered the leads in place, trim and discard the excess lead length.

## Step 6: 30K TH resistor (R6)

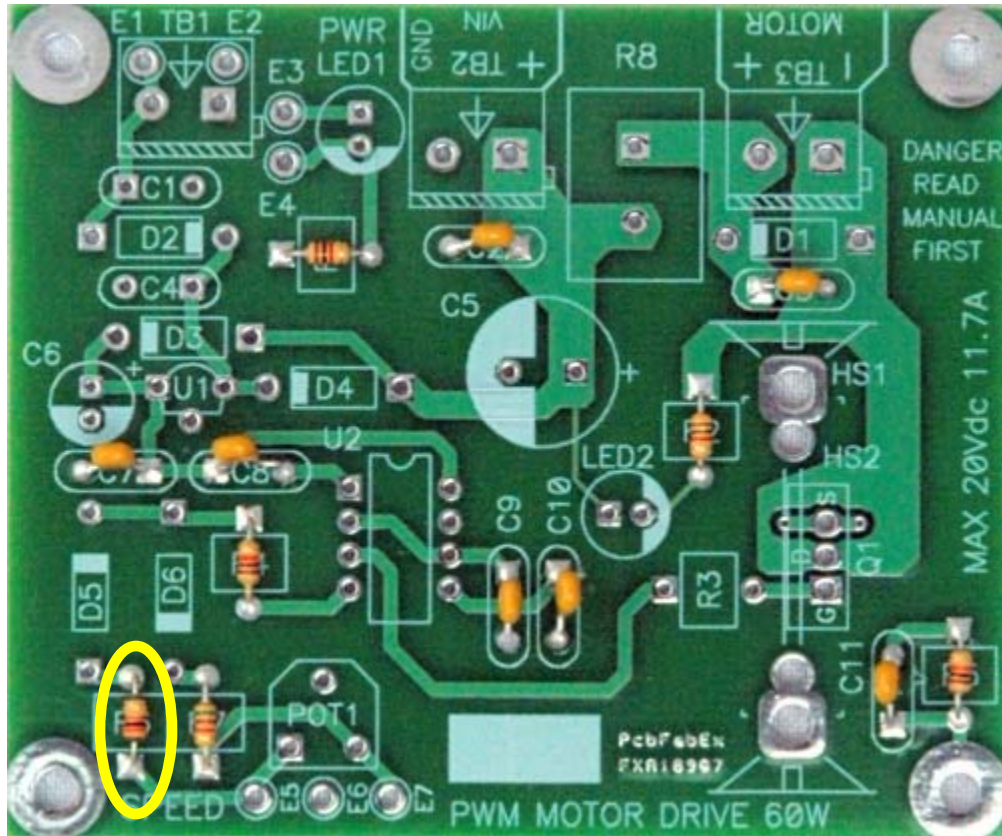

Figure 9: Board with 30K resistor installed.

From the kit, locate 1 piece of the 30K resistor.

Find the location for this part on the board, marked R6.

At this location, insert the resistor's leads through the plated holes.

On the back side of the board, bend the leads at 90-degree angles so that the parts are held in place when you solder them. Once you've soldered the leads in place, trim and discard the excess lead length.

## Step 7: 120 ohm TH resistor (R3)

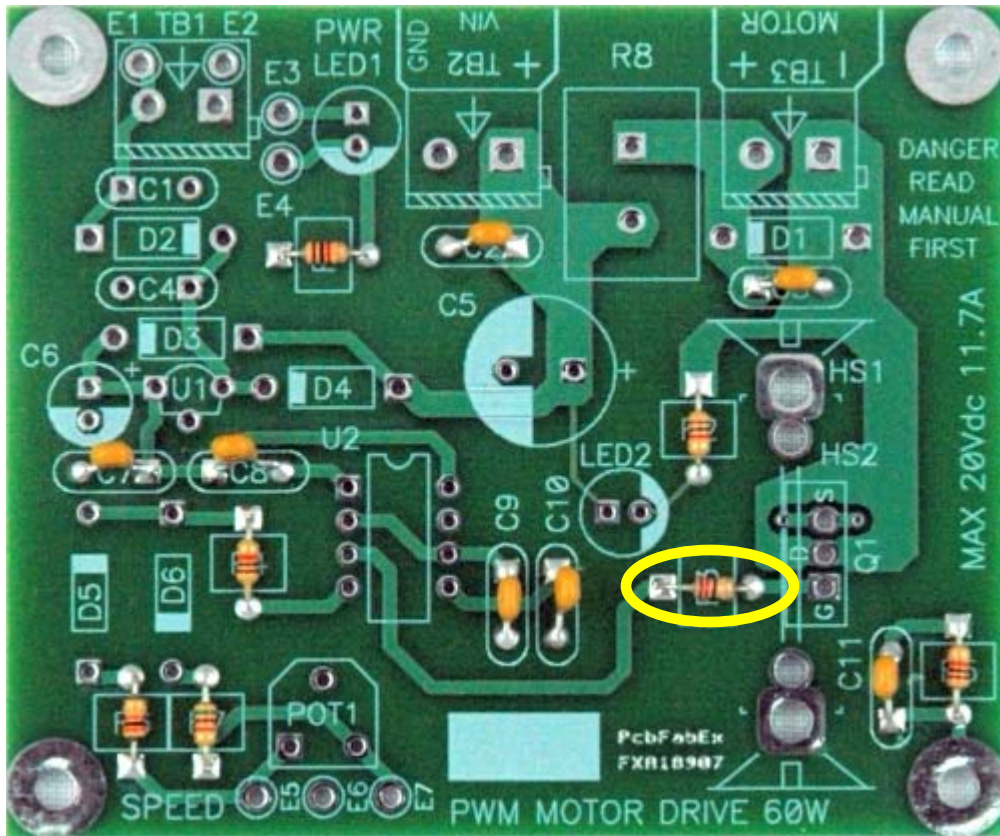

Figure 10: Board with 120 ohm resistors installed.

From the kit, locate 1 piece of the 10K resistor.

Find the location for this part on the board, marked R3.

At this location, insert the resistor's leads through the plated holes.

On the back side of the board, bend the leads at 90-degree angles so that the parts are held in place when you solder them. Once you've soldered the leads in place, trim and discard the excess lead length.

## Step 8: 1N4004 1A, 400V TH GP diodes, QTY 2 D1 & D3

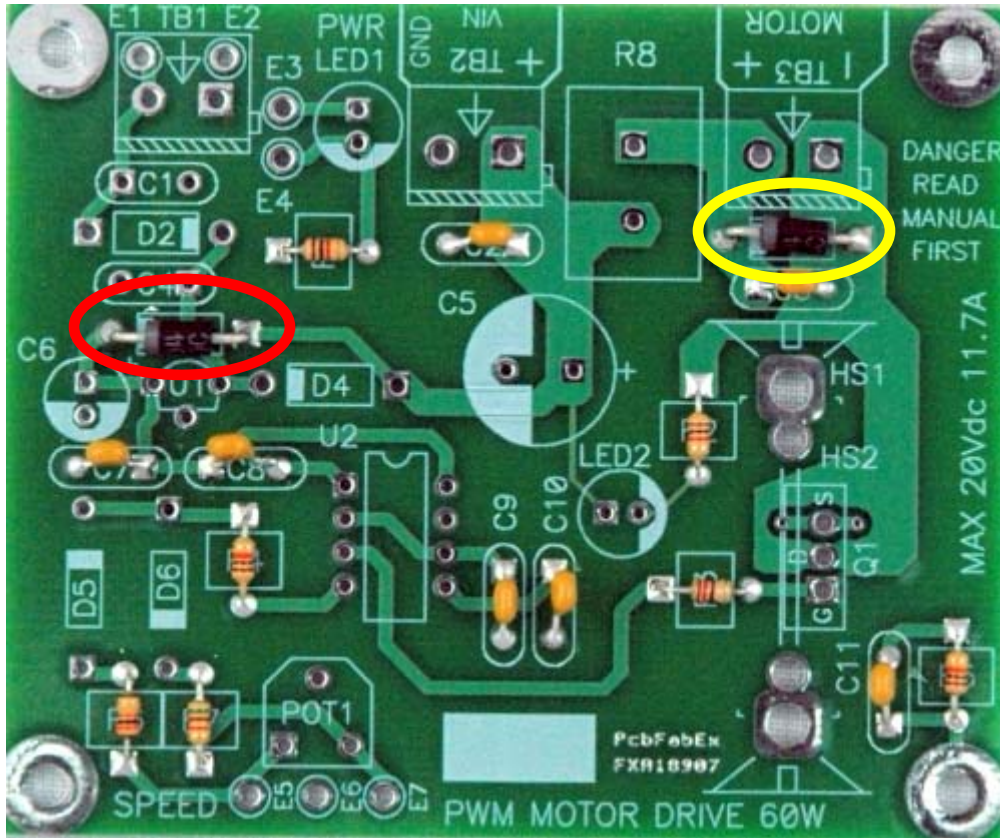

Figure 11: Board with 400V, 1A general-purpose diodes installed.  
From the kit, locate 2 pieces of the 400V, 1A general-purpose diodes.

Find the locations for these parts on the board, marked D1 & D3. If you intend to install the optional 5V supply, omit D3 (red circle) entirely.

At each location, insert the diode's leads through the plated holes. Make certain you line up the polarity markings on the device with the polarity markings on the board.

On the back side of the board, bend the leads at 90-degree angles so that the parts are held in place when you solder them. Once you've soldered the leads in place, trim and discard the excess lead length.

## Step 9: 4148 switching diodes, QTY 2 D5 & D6

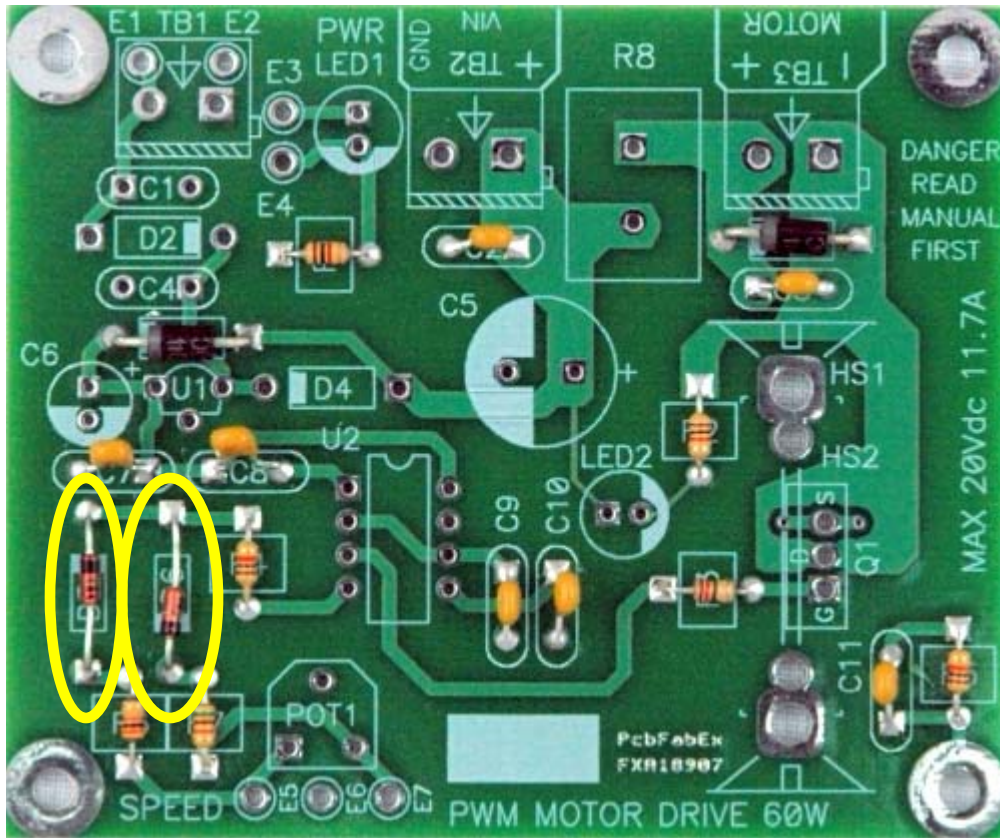

Figure 12: Board with 4148 switching diodes installed.

From the kit, locate 2 pieces of the 4148 switching diodes.

Find the locations for these parts on the board, marked D5 & D6.

At each location, insert the diode's leads through the plated holes. Make certain you line up the polarity markings on the device with the polarity markings on the board.

On the back side of the board, bend the leads at 90-degree angles so that the parts are held in place when you solder them. Once you've soldered the leads in place, trim and discard the excess lead length.

## Step 10: 1 green LED (LED1)

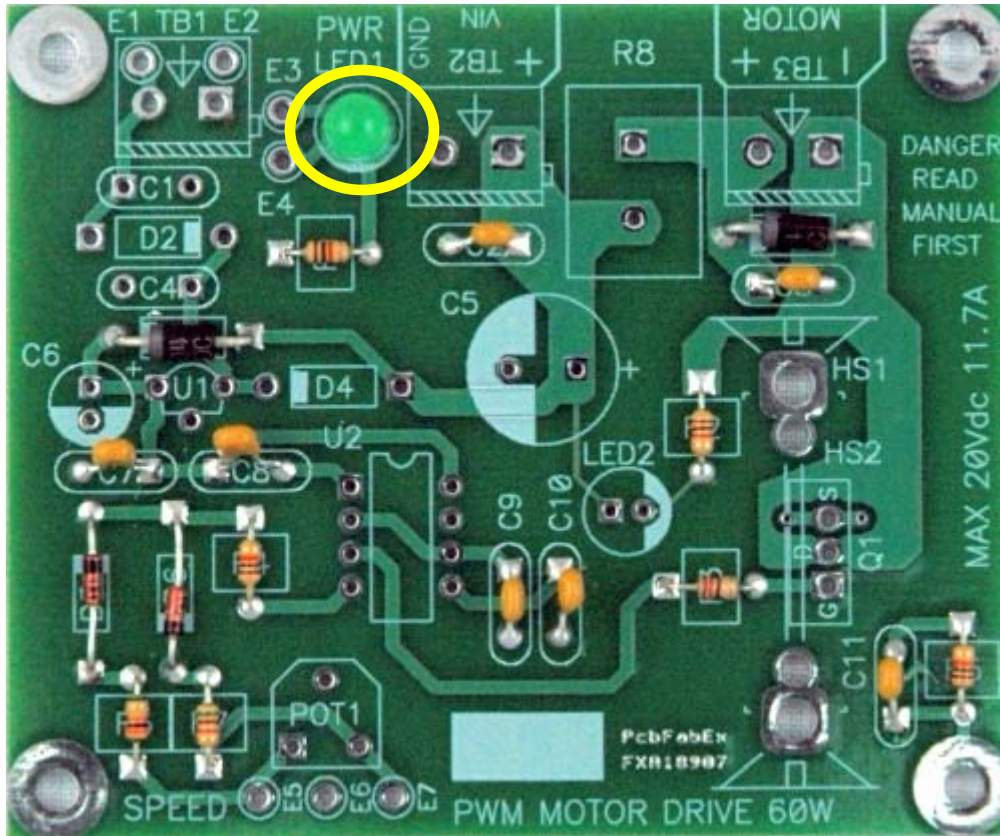

Figure 13: Board with green LED installed.

From the kit, locate 1 of the green LEDs.

Find the location for this part on the board, marked LED1.

At this location, insert the LED's leads through the plated holes. Make certain you line up the polarity markings on the device with the polarity markings on the board.

On the back side of the board, bend the leads at 90-degree angles so that the parts are held in place when you solder them. Once you've soldered the leads in place, trim and discard the excess lead length.

## Step 11: 1 red LED (LED2)

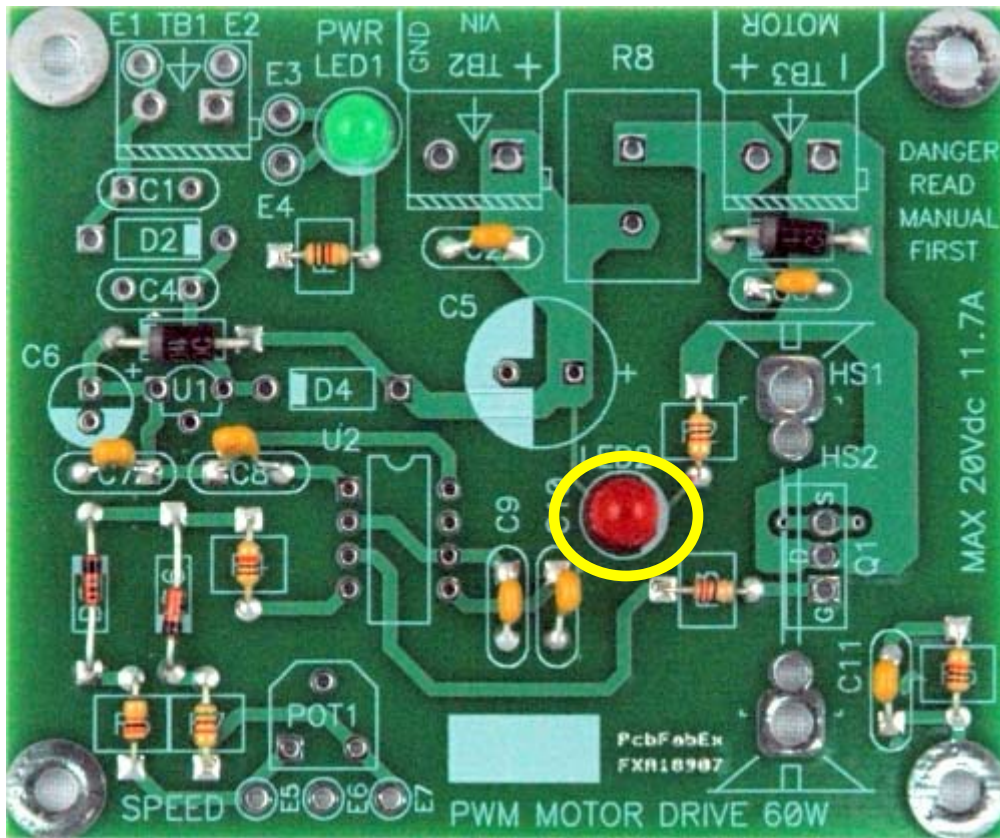

Figure 14: Board with red LED installed.

From the kit, locate 1 of the red LEDs.

Find the location for this part on the board, marked LED2.

At this location, insert the LED's leads through the plated holes. Make certain you line up the polarity markings on the device with the polarity markings on the board.

On the back side of the board, bend the leads at 90-degree angles so that the parts are held in place when you solder them. Once you've soldered the leads in place, trim and discard the excess lead length.

## Step 12: 5.0K potentiometer (POT1)

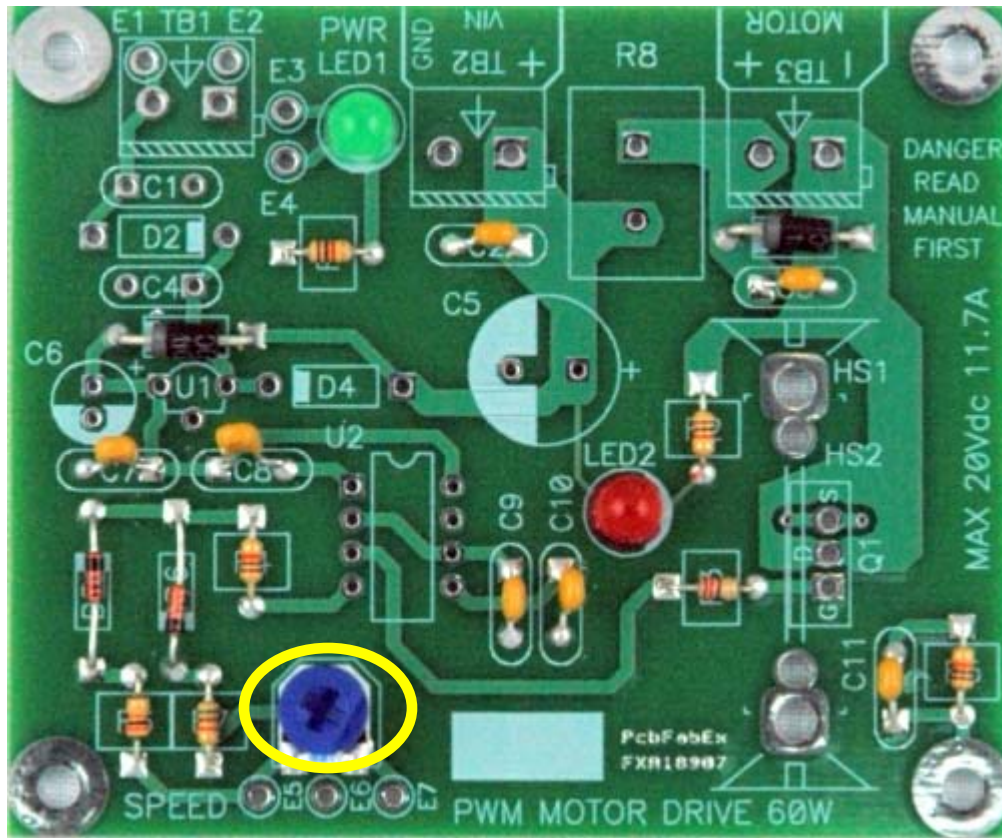

Figure 15: Board with potentiometer installed.

From the kit, locate 1 of the 5.0K potentiometers.

Find the location for this part on the board, marked POT1.

At this location, snap the potentiometer's leads through the plated holes and solder them in place.

PLEASE NOTE: The potentiometer has corresponding wire holes (E5, E6, and E7) for mounting a remote switch if desired.



## Step 13: 555 timer and socket (U2)

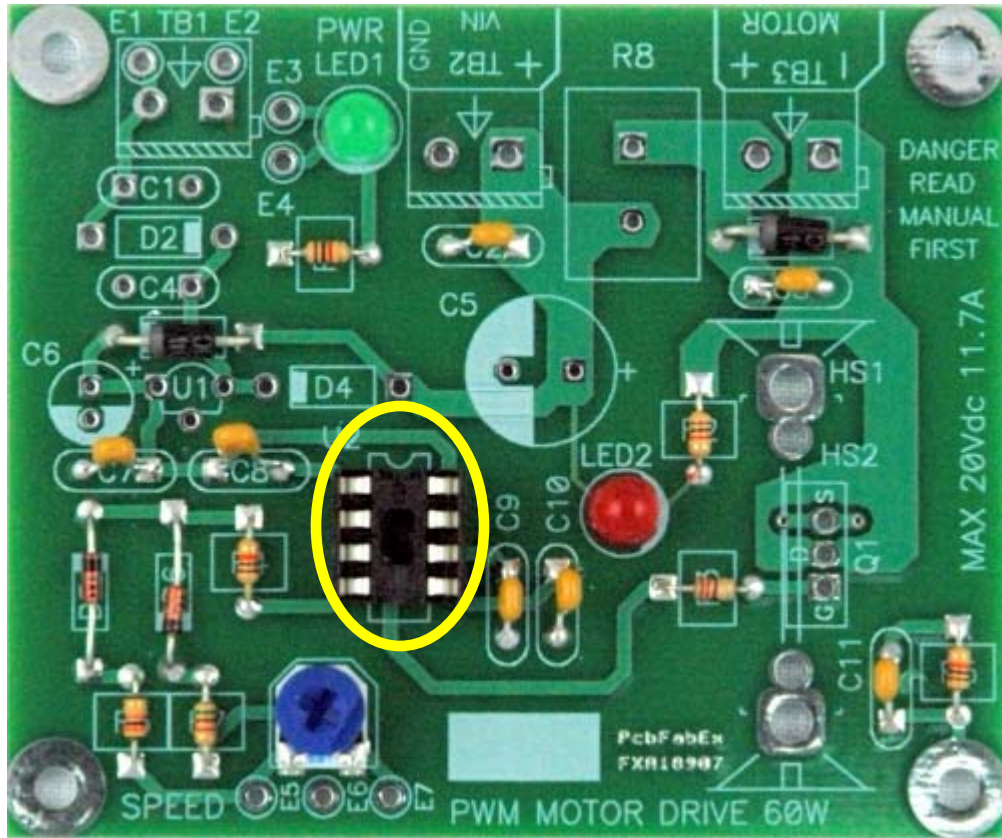

Figure 16: Board with socket and 555 timer installed.

From the kit, locate 1 of the 8-pin sockets and the 555 timer chip.

Find the location for these parts on the board. It is marked U2.

At this location, insert the socket's leads through the plated holes and solder them in place.

Carefully insert the 555 timer into the socket, making sure to line up the pin 1 indicator on the socket with the pin one indicator on the body of the processor.

## Step 14: 330uF TH electrolytic capacitor (C5)

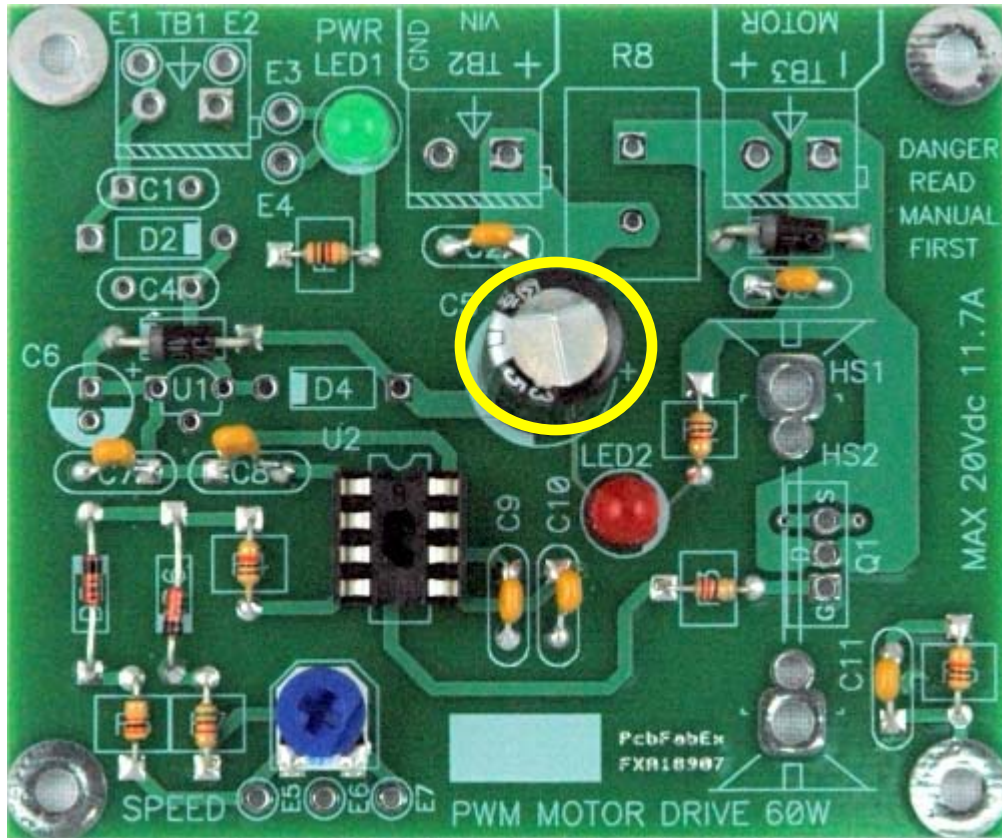

Figure 17: Board with aluminum electrolytic capacitors installed.

From the kit, locate 1 piece of the 330uF capacitors.

Find the location for this part on the board, marked C5.

At this location, insert the capacitor's leads through the plated holes. Make certain you line up the polarity markings on the device with the polarity markings on the board.

On the back side of the board, bend the leads at 90-degree angles so that the parts are held in place when you solder them. Once you've soldered the leads in place, trim and discard the excess lead length.

## Step 15: 0.1 ohm TH resistor (R8)

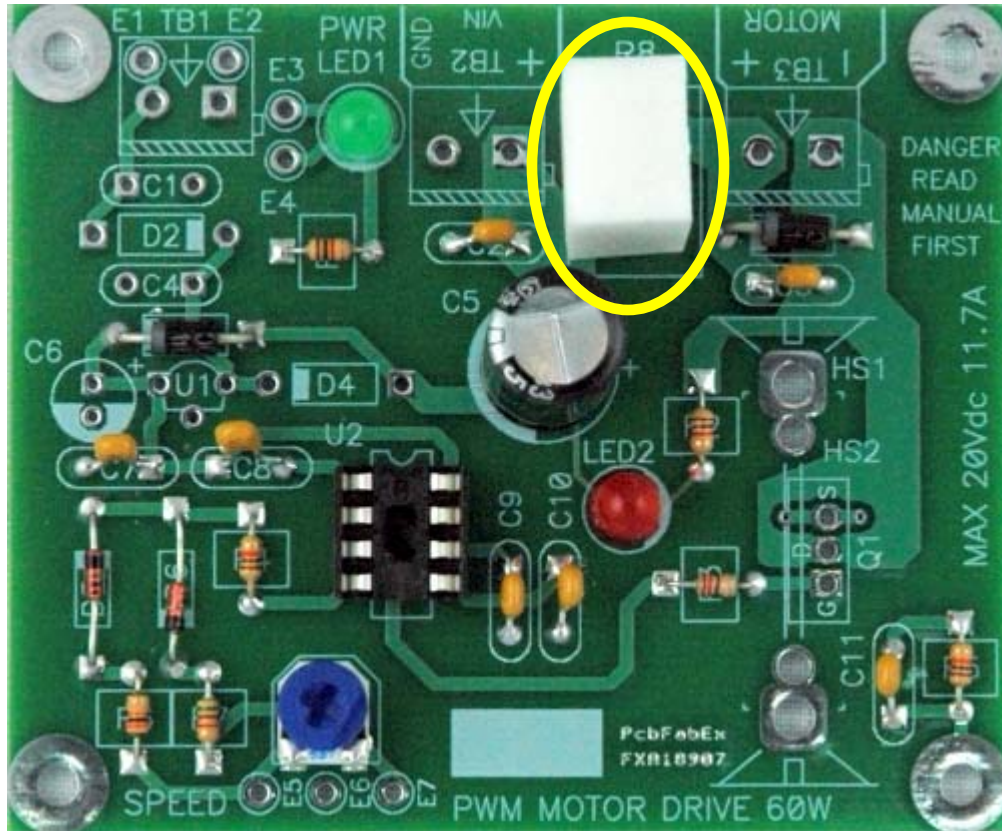

Figure 18: Board with 0.1 ohm resistor installed.

From the kit, locate 1 piece of the 0.1 ohm resistors.

Find the location for this part on the board, marked R8.

At this location, insert the resistor's leads through the plated holes.

On the back side of the board, bend the leads at 90-degree angles so that the parts are held in place when you solder them. Once you've soldered the leads in place, trim and discard the excess lead length.

## Step 16: 2-pin terminal blocks, QTY 2 TB2, TB3

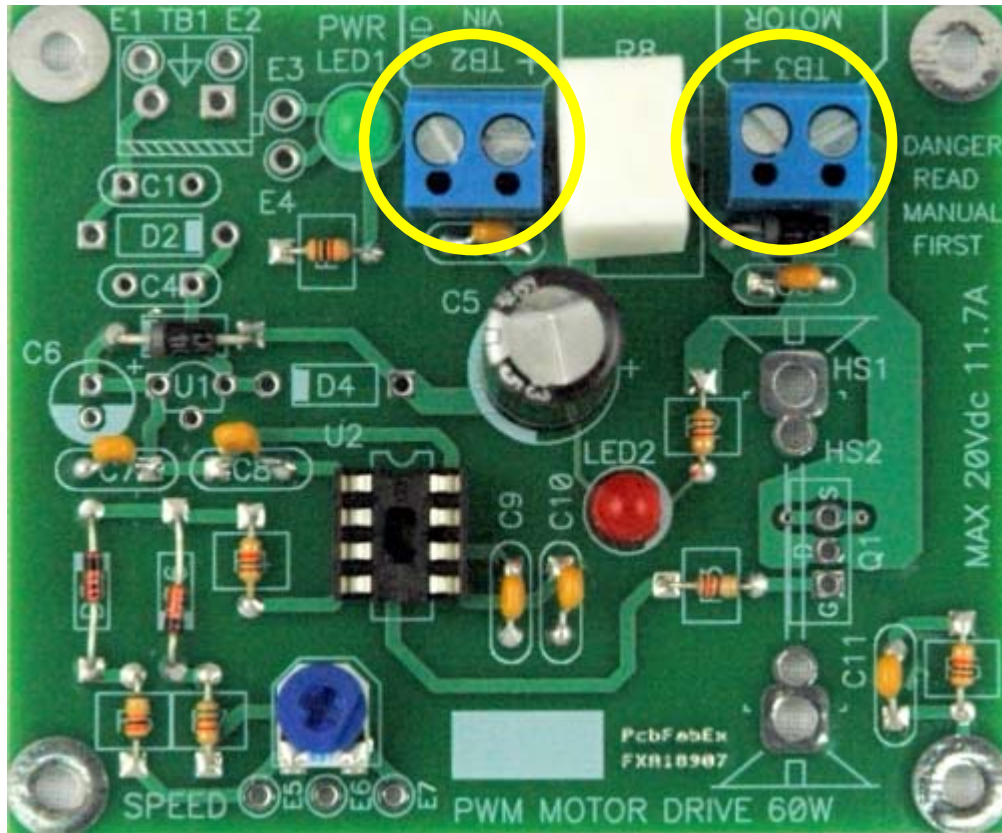

Figure 19: Board with terminal blocks installed.

From the kit, locate 2 of the 2-pin terminal blocks.

Find the location for these parts on the board, marked TB2 & TB3.

At each location, insert the block's leads through the plated holes and solder them in place.

## Step 17: NPN transistor (Q1)

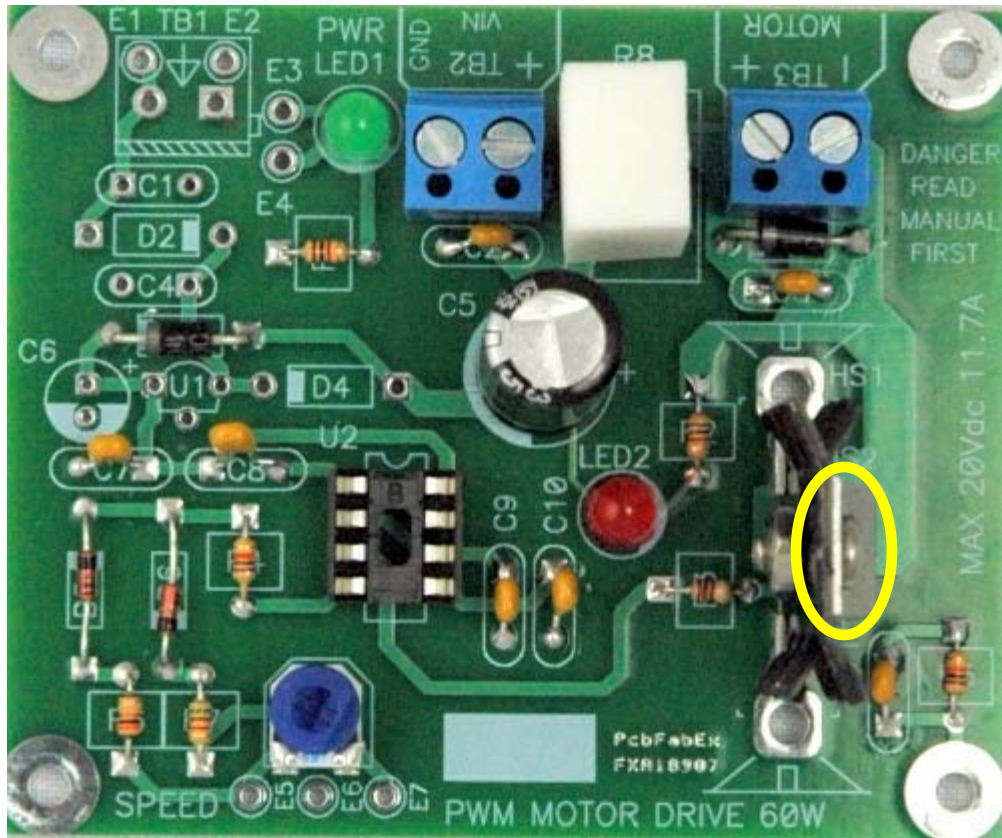

Figure 20: Board with MOSFET installed.

From the kit, locate 1 of the NPN transistors.

Find the location for this part on the board, marked Q1.

At this location, insert the transistor's leads through the plated holes and solder them in place.

## Step 18: Heat Sink (HS1/HS2)

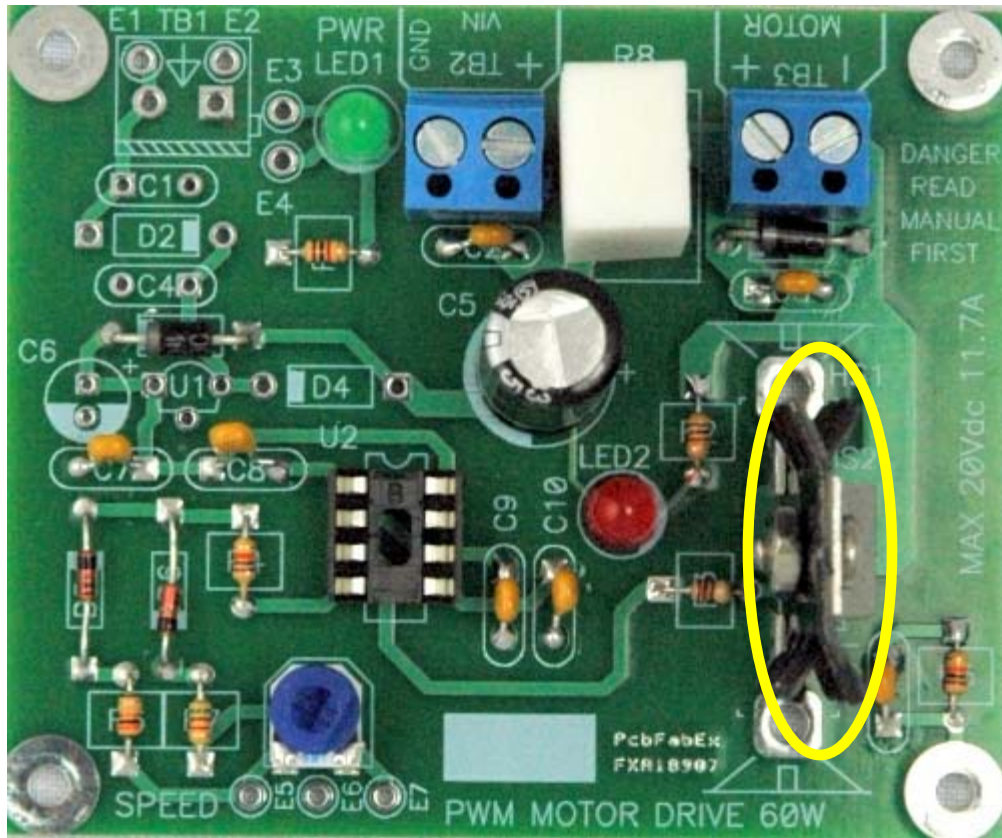

Figure 21: Board with heat sink installed.

From the kit, locate the heat sink.

Find the location for these parts on the board, marked HS1, directly behind Q1.

At this location, insert the heat sink's tabs through the plated holes. Screw Q1's tab into the hole in the middle of the heat sink.

Solder the heat sink's tabs into place.

# Optional 5V Regulator



## Step 19: 100uF TH electrolytic capacitor (C6)

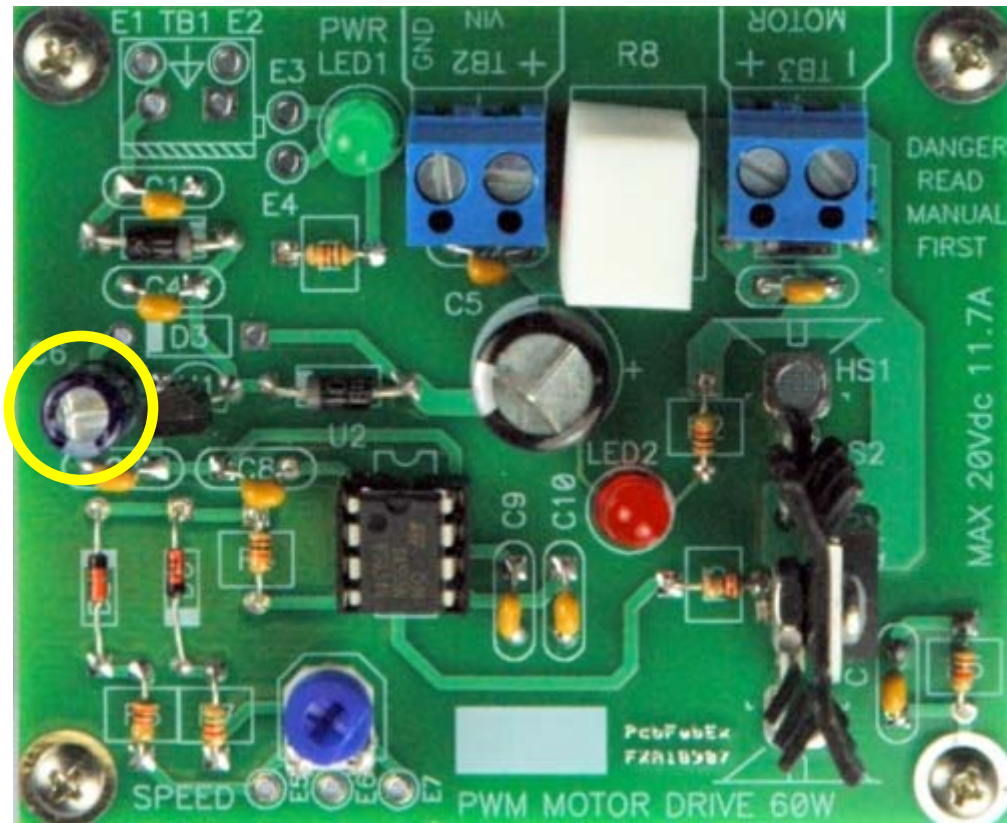

Figure 22: Board with aluminum electrolytic capacitors installed.

From the kit, locate 1 piece of the 100uF capacitors.

Find the location for this part on the board, marked C6.

At this location, insert the capacitor's leads through the plated holes. Make certain you line up the polarity markings on the device with the polarity markings on the board.

On the back side of the board, bend the leads at 90-degree angles so that the parts are held in place when you solder them. Once you've soldered the leads in place, trim and discard the excess lead length.



## Step 20: 0.1uF TH ceramic capacitors, QTY 2 C1, C4

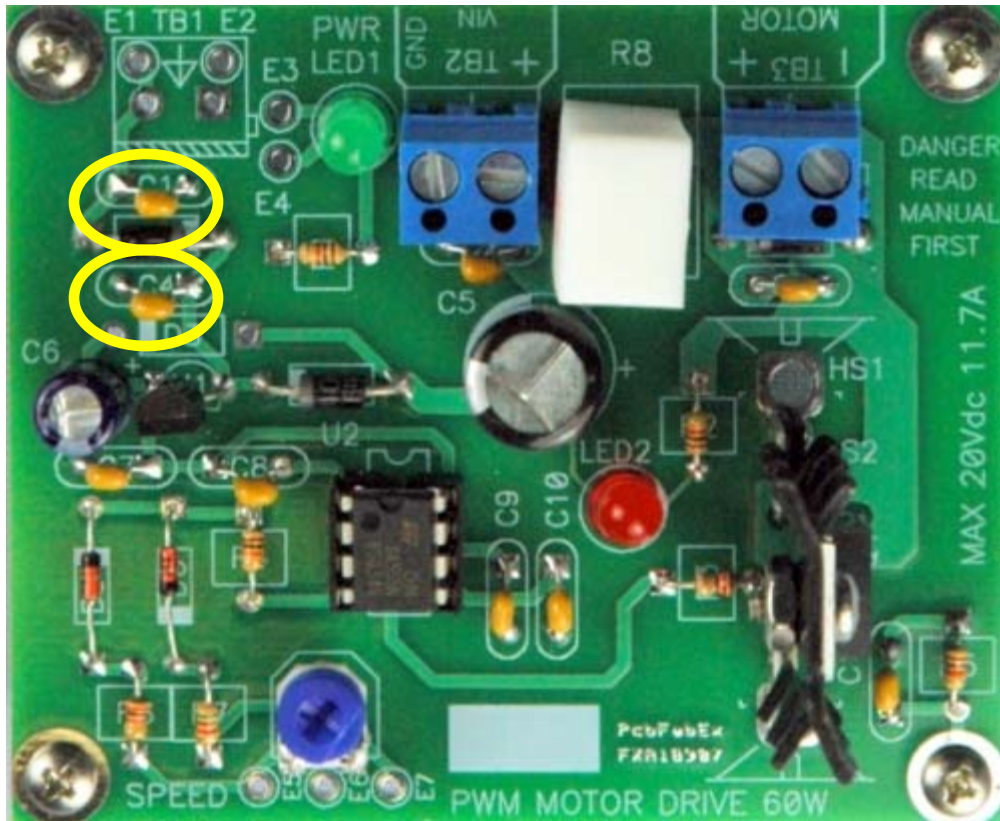

Figure 23: Board with 0.1uF ceramic capacitors installed.

From the kit, locate 2 pieces of the 0.1uF ceramic capacitor.

Find the locations for these parts on the board, marked C1 & C4.

At each location, insert the capacitor's leads through the plated holes.

On the back side of the board, bend the leads at 90-degree angles so that the parts are held in place when you solder them. Once you've soldered the leads in place, trim and discard the excess lead length.

## Step 21: 5V TH regulator (U1)

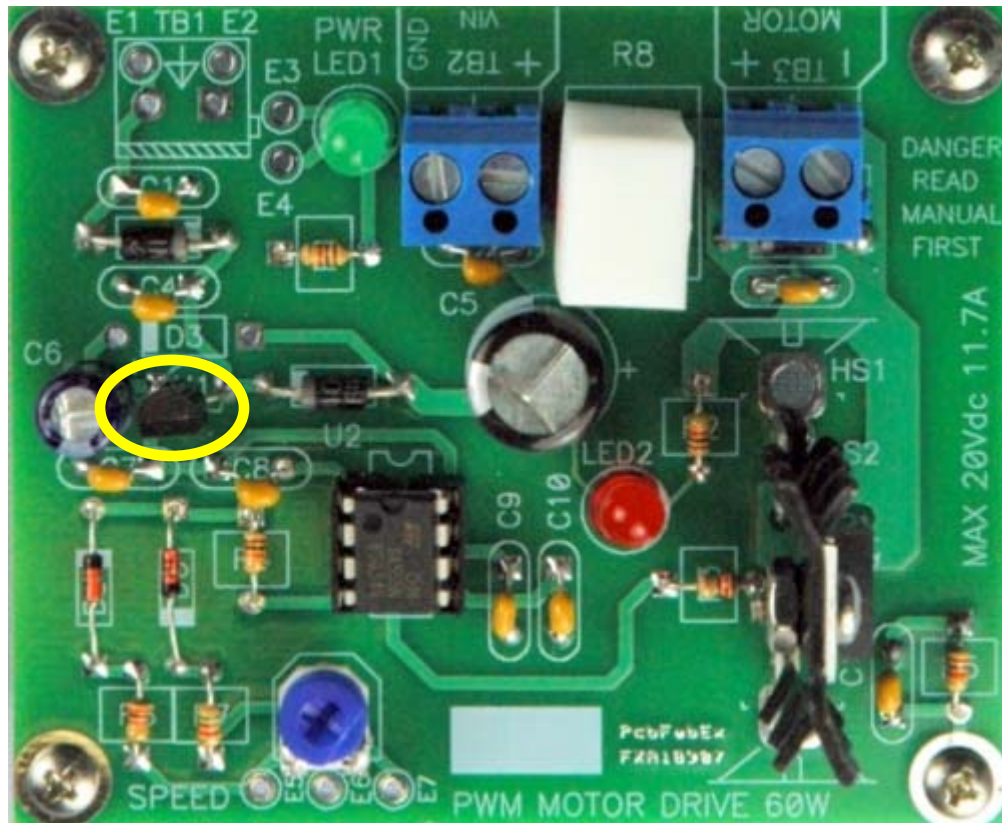

Figure 24: Board with 5V regulator installed.

From the kit, locate 1 of the 5V regulators.

Find the location for this part on the board, marked U1.

At this location, insert the regulator's leads through the plated holes and solder them in place.

## Step 22: 1N4004 1A, 400V TH GP diodes, QTY 2 D2 & D4

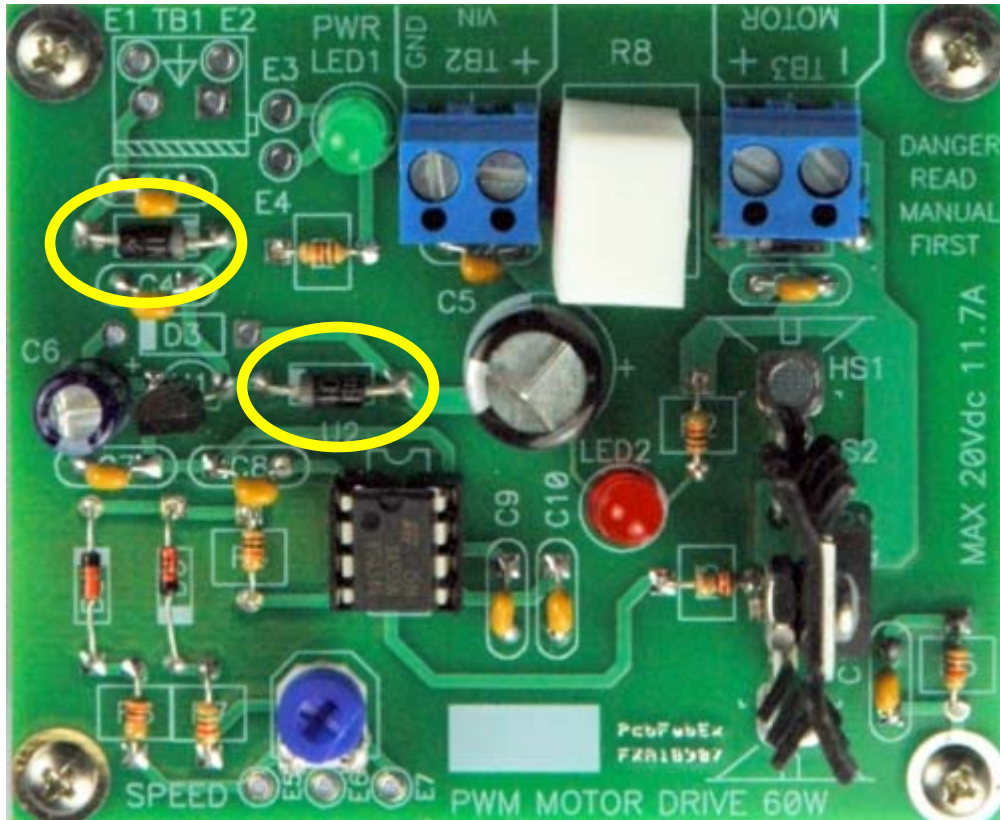

Figure 25: Board with 400V, 1A general-purpose diodes installed.

From the kit, locate 2 pieces of the 400V, 1A general-purpose diodes.

Find the locations for these parts on the board, marked D2 & D4.

At each location, insert the diode's leads through the plated holes. Make certain you line up the polarity markings on the device with the polarity markings on the board.

On the back side of the board, bend the leads at 90-degree angles so that the parts are held in place when you solder them. Once you've soldered the leads in place, trim and discard the excess lead length.

# Configuration for Separate Timer / Driver Power Supplies

If you wish to use separate power supplies for the 555 timer and the driver portions of the design:

- 1) Stuff the board as normal for the optional 5V power supply, EXCEPT that you omit D3 & D4
- 2) Stuff TB1

# Customer Service & Support

We have done our very best to provide you with a product that was designed and manufactured by experienced professionals.

Our assembled units are visually inspected and functionally tested.

Whether you're buying assembled units or unassembled kits from us, our goal is to ensure 100% customer satisfaction on every product, every sale, every time.

If for any reason you are unsatisfied with this product and wish to return it, please visit our web site and go to our Customer Service page to view our latest return policies.

We thank you for your trust and your business, and hope to hear from you in the future!

# Disclaimers

THIS PRODUCT IS PROVIDED "AS-IS," "AS AVAILABLE," AND ALL WARRANTIES, EXPRESS OR IMPLIED, ARE DISCLAIMED (INCLUDING BUT NOT LIMITED TO THE DISCLAIMER OF ANY IMPLIED WARRANTIES OF MERCHANTABILITY AND FITNESS FOR A PARTICULAR PURPOSE). THE SOLE AND ENTIRE MAXIMUM LIABILITY OF CADX SERVICES, INC., FOR ANY REASON, AND BUYER'S SOLE AND EXCLUSIVE REMEDY FOR ANY CAUSE WHATSOEVER, SHALL BE LIMITED TO THE AMOUNT PAID BY THE CUSTOMER FOR THE PARTICULAR ITEMS PURCHASED. CADX SERVICES, INC. AND ANY OF ITS AFFILIATES, DEALERS OR SUPPLIERS ARE NOT LIABLE FOR ANY INDIRECT, SPECIAL, INCIDENTAL, OR CONSEQUENTIAL DAMAGES (INCLUDING DAMAGES FOR LOSS OF BUSINESS, LOSS OF PROFITS, LITIGATION, OR THE LIKE), WHETHER BASED ON BREACH OF CONTRACT, BREACH OF WARRANTY, TORT (INCLUDING NEGLIGENCE), PRODUCT LIABILITY OR OTHERWISE, EVEN IF ADVISED OF THE POSSIBILITY OF SUCH DAMAGES. THE LIMITATIONS OF DAMAGES SET FORTH ABOVE ARE FUNDAMENTAL ELEMENTS OF THE BASIS OF THE BARGAIN BETWEEN CADX SERVICES, INC. AND BUYER. THIS PRODUCT WOULD NOT BE PROVIDED WITHOUT SUCH LIMITATIONS. SOME STATE STATUTES MAY APPLY REGARDING LIMITATION OF LIABILITY.

# Software License

In the interests of making life simple, here is a simple software license agreement.

By making use of the software included in this kit (“Software”), you are agreeing to be bound by the following:

## Use

You can use the Software for anything you like.

## Distribution

If you want to distribute the Software, you must include in the distribution everything that you got when you received the Software (including this license agreement) and give first credit to CADX Services, Inc.

## Derivative Works

If you modify the Software or use all or a portion of the Software in your own work, you must give credit to CADX Services, Inc. for the original work.

## Liability

If anything goes wrong as a result of the use or modification of the Software, or the use or modification of derivative works created from the Software, it is solely your responsibility.

We’ve worked hard to include the highest quality software with this product; nevertheless, the Software, this product and this documentation are provided “as-is.”